

PERT-AL-PERT DATA SHEET

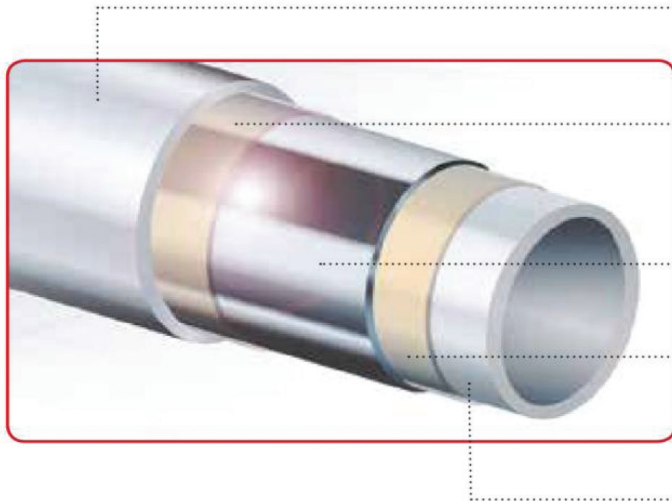

Outer Layer - Polyethylene raised temperature (PE-RT) plastic coat: protects the aluminium core and allows the outer shell to be coloured without contaminating the water.

Adhesive Layer - Interface zone between the outer PE-RT layer and the aluminium core. Bonds the materials together and prevents shear slippage.

Aluminium Layer - Thin layer of overlap welded aluminium which forms a 100% oxygen barrier to protect against corrosion and allows the pipe to have the 'formstable' characteristic.

Adhesive Layer - Interface zone between the inner PE-RT layer and the aluminium core. Bonds the materials together and prevents shear slippage.

Inner Layer - Inner layer of clear PE-RT. Inert and does not affect the water in any way. Allows for a smooth wall surface to reduce pressure drops for water flow.

Multilayer PIPE:

Multilayer Pipe is a premium multilayer composite pipe with an aluminium layer. This provides excellent strength, a 100% oxygen barrier, and it holds its shape when bent.

Technical:

Material: PE-RT / AL / PE-RT
Diameter: 16mm x 2mm
Internal diameter: 11.95mm ± 0.1mm
Minimum bend radius: 80mm
Weight: 0.102kg/m
Water volume: 0.113L/min

Features:

Holds its shape when bent for simple installation
5-layer 100% oxygen barrier
Coil lengths:
50m, 80m, 100m, 200m, 300m, 500m
Suitable for all 16mm fitting systems
50 year design life
Marked every metre

Thermal properties:

Conductivity: 0.42W/mK
Coefficient of expansion: 0.025mm/mK

Operating pressure and temperature:

Normal operating temperature to: 60°C
Normal operating pressure to: 6 bar
Minimum failure temperature: 95°C
Minimum failure pressure: 10 bar

Accreditations:

DVGW W542
DIN EN ISO 21003

USE:

Drinking water installation
Radiator connection
Underfloor heating

