



## 1.0 SAFETY INFORMATION

- The provision of the electrical supply and the connection of the unit to the electrical supply must be carried out by a qualified electrician in accordance with latest edition of the wiring regulations.
- Isolate from power supply before removing any covers. During installation / maintenance ensure all covers are fitted before switching on the mains supply.
- All-pole disconnection from the mains as shown in the wiring diagram must be incorporated within the fixed wiring and shall have a minimum contact separation of 3mm in accordance with latest edition of the wiring regulations.
- This unit must be earthed.
- Ducting must be securely fixed with screws to the spigot to prevent access to live parts. Duct runs terminating close to the fan must be adequately protected by suitable guards.
- If the supply cord is damaged, it must be replaced by the manufacturer, its service agent or similarly qualified persons in order to avoid a hazard. The replacement cord must be of the same technical specification as the original cord or greater.
- Precautions must be taken to avoid the back-flow of gases into the room from the open flue of gas or other fuel-burning appliances.
- This appliance should not be used by children or persons with reduced physical, sensory or mental capabilities or lack of experience and knowledge, unless they have been given supervision or instruction concerning the safe use of the appliance by a person responsible for their safety. Children shall not play with the appliance. Cleaning and user maintenance shall not be carried out by children.

### 1.1 Hazard Symbols



#### **REFER TO INSTRUCTION MANUAL**

Read and understand the installation and maintenance manual before installing, operating or maintaining this product.

### 1.2 Important Information

This manual contains important information on the safe and appropriate assembly, transport, commissioning, operation, maintenance, disassembly and simple troubleshooting of the product.

While the product has been manufactured according to the accepted rules of current technology, there is still a danger of personal injury or damage to equipment if the following general safety instructions and the warnings contained in these instructions are not complied with.

- **Read these instructions completely and thoroughly before working with the product.**
- **Keep these instructions in a location where they are accessible to all users at all times.**
- **Always include the operating instructions when you pass the product on to third parties.**

### 1.3 Personal Protective Equipment

The following minimum Personal Protective Equipment (PPE) is recommended when interacting with Nuaire product:

- **Protective Steel Toed Shoes** - when handling heavy objects.
- **Full Finger Gloves (Marigold PU800 or equivalent)** - when handling sheet metal components.
- **Semi Fingerless Gloves (Marigold PU3000 3DO or equivalent)** - when conducting light work on the unit requiring tactile dexterity.
- **Safety Glasses** - when conducting any cleaning/cutting operation or exchanging filters.
- **Reusable Half Mask Respirators** - when replacing filters which have been in contact with normal room or environmental air.

Nuaire would always recommend a site specific risk assessment by a competent person to determine if any additional PPE is required.

## 2.0 INTRODUCTION

The LP2 ceiling void mounted unit is designed to provide mechanical supply and extract ventilation with heat recovery and incorporates HX bypass.

The unit is fitted with two independent fans. Each fan has full speed control for background and boost ventilation rates. To recover heat from the extract air the heat exchanger block is utilised. The heat exchanger can recover up to 80% of the normally wasted heat.

**The unit must remain switched on at all times to maintain ventilation within the dwelling. Turning the unit off will cause long term damage to the unit and building fabric.**

**This appliance is not intended for use by persons (including children) with reduced physical, sensory or mental capabilities, or lack of experience and knowledge, unless they have been given supervision or instruction concerning the use of the appliance by a person for their safety. Children should be supervised so that they do not play with the appliance.**

### 1 Unit Airflow Paths (Standard Unit Configuration)

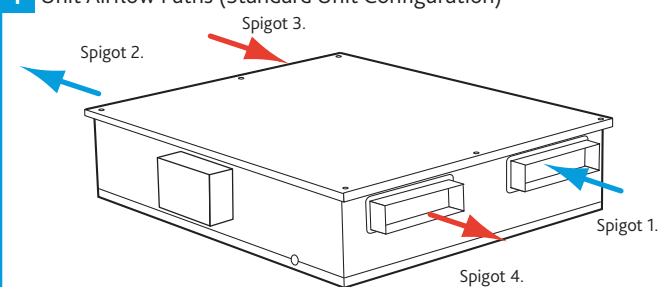

#### Spigots 1 to 4

1. Intake Air (Fresh air from outside).
2. Supply Air (Supply in to house).
3. Extract Air (Warm stale air from house).
4. Exhaust Air (Waste air to outside).

### 2 Unit Airflow Paths (Opposite Hand Unit Configuration)

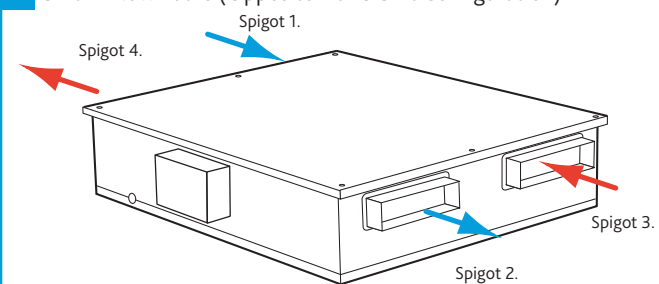

#### Spigots 1 to 4

1. Intake Air (Fresh air from outside).
2. Supply Air (Supply in to house).
3. Extract Air (Warm stale air from house).
4. Exhaust Air (Waste air to outside).

## 3.0 MECHANICAL INSTALLATION

Installation must be carried out by competent personnel in accordance with the appropriate authority and conforming to all statutory governing regulations. All mains wiring must be in accordance with the current I.E.E. Regulations, or the appropriate standards. Ensure that the mains supply (Voltage, Frequency and Phase) complies with the rating label.

Please note a clear working space is required around the installed unit to allow the cover to be removed and provide sufficient access for maintenance such as filter change.

The fan must be installed indoors, in a suitable ceiling void away from direct sources of frost, heat, water spray or moisture generation. For a vibration-free result the unit must be mounted to a solid surface in the void.

The unit is designed for ceiling mounting only (Horizontal surface).

The unit is supplied with a steel mounting bracket.

Position & secure the steel bracket to the ceiling using appropriate fixings (supplied by others), ensuring that the two outer fixing holes on the unit are accessible (Figure 3).

**The mounting bracket should be on the same side as the condensate take off.**

3. The unit can now be offered into position & located into the mounting bracket.

4. Using appropriate fixings (supplied by others) fix the unit to the ceiling. It is recommended that the unit is fixed through three holes on the non-bracket side and the two outer holes on the bracket side.

**The unit must be installed in an upright position as shown for the condensate drain and for compliance with safety regulations relating to IP protection for water drip ingress.**

### 3 Standard Unit Mounting Using Appropriate Fixing Bolts

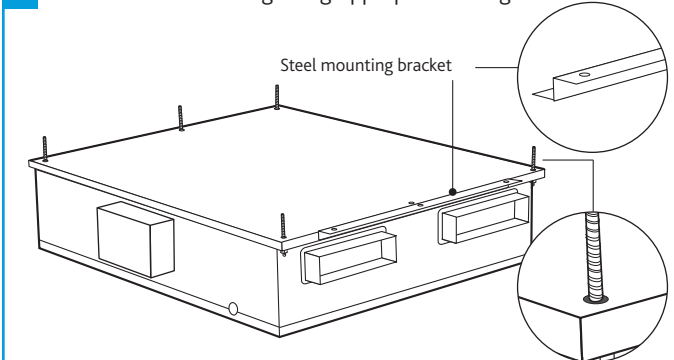

### 4 Side View Of Standard Unit Typical Ceiling Void Installation Using 204 x 60 mm Rectangular Ducting & Air Valves

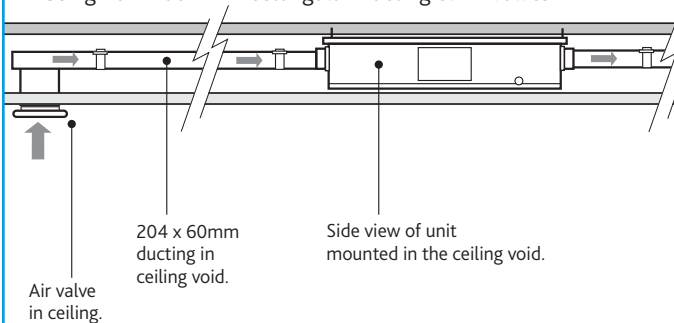

## 3.1 Condensate Drain Installation

- Unit comes complete with external drain pipe (21.5mm waste pipe). Use conventional plumbing connections to link up with U-trap or alternative drain method (Solvent cement connections or compression fit connections are recommended). The condensate must be discharged under a water level in a U-trap drainpipe or an alternative drain method which acts as an airlock.
- This condensate discharge connection is suitable for 21.5mm dia. overflow pipe. Solvent cement should be used to make the joint.
- If using a U-trap please ensure the U-trap has been filled to a suitable level of water to avoid any air locks.
- If the condensation pipe is fitted in an unheated space the pipe should be in insulated to prevent freezing.

Nuair recommend MVHR-DRAIN be used as the primary condensate take-off (Figure 5 and 6).

**5** Typical Condensate Pipe Connection Using MVHR-DRAIN Ancillary

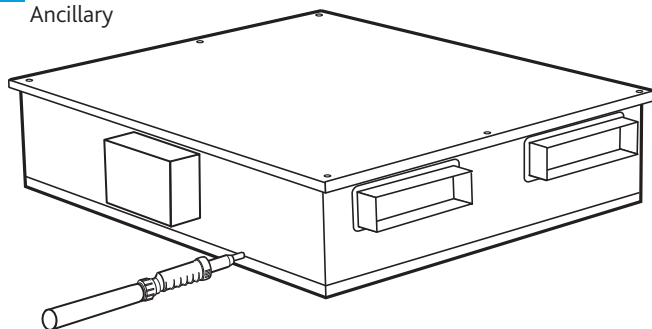

**6** MVHR-DRAIN Installation

**CORRECT**

**INCORRECT**

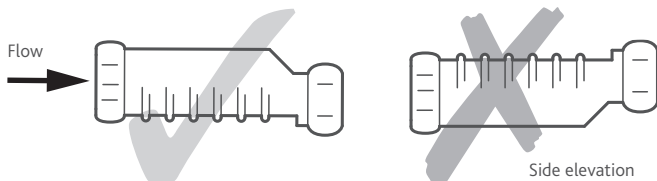

When installed horizontally the ribs must be at the bottom to ensure correct operation.

**3.1.1 MVHR-DRAIN Installation**

Offer up the MVHR-DRAIN inlet to the threaded tail of the appliance waste outlet or MVHR-DRAIN knuckle or running adaptor, and tighten the threaded cap sufficiently hand-tight to provide a water-tight seal (check that the cap screws on square and does not 'cross-thread'). When the screwed cap is tight, the MVHR-DRAIN body is secure.

- Cut the pipe to length, allowing for the full compression socket depth (using an appropriate pipe cutter, such as a Hepworth ratchet pipe cutter).
- Remove any 'swarf' from the end of the plastic pipe. Ream the copper pipe end to remove any 'burr', and file if necessary to remove any external sharp edges. Mark the socket depth on the pipe, and check that the pipe section to be jointed is free of any surface damage which may affect the joint seal.
- Unscrew the cap from the MVHR-DRAIN outlet, and slide the cap and rubber seal onto the pipe.
- Insert the pipe end fully into the socket.
- Slide the rubber seal and screwed cap up against the face of the socket, and tighten the cap sufficiently hand-tight (check that the cap is square to the body and does not 'cross thread'). Hand tight should be adequate to form a proper seal.

**3.2 Extract & Supply Areas**

The unit is designed to extract air from all wet rooms e.g. bathroom, kitchen, en-suite, utility room (with sink).

WC's do not need to be ventilated if openable windows are fitted.

Supply air should be to all habitable rooms e.g. bedrooms and lounge. Extract & Supply grilles should be adjustable valve types (not supplied).

External grilles must have a minimum free area of 12,250 mm<sup>2</sup>.

**3.3 Ducting Installation**

Before commencing ducting installation reference should be made to building regulations document "Domestic ventilation compliance guide". This document supports ADF2010 and details installation, testing and commissioning of all ventilation systems.

It is recommended that rigid ducting must be used it all times. Flexible ducting has a very high resistance and it is impossible to calculate how much resistance will be on a system if used. If used the flexible ducting must be kept to a minimum and should always be pulled taut. A maximum of 300mm should be used on each leg.

To prevent condensation on the outside of the outside air inlet duct and the air outlet duct from the MRXBOXAB-ECO-LP2, these ducts should be insulated.

Ducting must be installed in such a way that resistance to airflow is minimised. Bends should be kept to a minimum.

A minimum distance of 300mm between the appliance and any bends in ductwork is recommended.

204 x 60mm rectangular ducting should be used (refer to dwelling ducting design drawing, Figures 8 & 10 for further information).

Ducting joints must be sealed with silicone type sealant and needs to be taped. Ducting shall be adequately and reliably fixed to the appliance.

**3.4 Ventilation Flow Rates**

**Any air intake terminal MUST be installed in accordance with the appropriate regulation.**

**As a guide, the BS5440 series of British Standards deals with this issue and currently states that an air intake must be at a minimum distance of 300mm from a gas boiler balanced flue.**

**Installers are advised to be aware of the requirements of this standard when installing 'through the wall' supply air ducting.**

**3.4.1 ADF 2010 - Extract Ventilation Rates**

Room	Min high rate	Min low rate
Kitchen	13 l/s	Total extract rate should be at least the whole dwelling ventilation rate given in table 2.
Utility Room	8 l/s	
Bathroom	8 l/s	
Sanitary Accommodation	6 l/s	

**3.4.2 Whole Dwelling Ventilation Rates**

	Number of bedrooms in dwelling				
	1	2	3	4	5
Whole dwelling ventilation rate (l/s)	13	17	21	25	29

**1. In addition, the minimum ventilation rate should be no less than 0.3 l/s per m<sup>2</sup> of internal floor area. (This includes all floors, e.g. for a two-story building add the ground and first floor areas).**

**2. This is based on two occupants in the main bedroom and a single occupant in all other bedrooms. This should be used as the default value. If a greater level of occupancy is expected add 4 l/s per occupant.**

### 3.5 ADF 2010 Ventilation Calculations Design of MVHR Systems

The MVHR system has been sized for the winter period. Additional ventilation may be required during the warmer months and it has been assumed that the provisions for purge ventilation (e.g. openable windows) could be used.

**Step 1:** For any design air permeability, determine the whole dwelling ventilation supply rate from **Table 2**.

As an alternative where the design air permeability is intended to be leakier than (>) 5m<sup>3</sup>/(h.m<sup>2</sup>) 50 Pa, allow for infiltration for all dwelling types by subtracting from the whole dwelling ventilation supply rate from Table 2; 0.04 x gross internal volume of the dwelling heated space (m<sup>3</sup>).

**Step 2:** Calculate the whole dwelling extract ventilation rate by summing the individual room rates for 'minimum high rate' from **Table 1**.

(For sanitary accommodation only, as an alternative, the purge ventilation provisions given in ADF 2010 can be used where security is not an issue. In this case 'minimum high extract rate' for the sanitary accommodation should be omitted from the step 2 calculation).

**Step 3:** The required airflow rates are as follows:

The maximum whole dwelling extract ventilation rate (e.g. boost) should be at least the greater of step 1 and step 2.

Note that the maximum individual room extract rate should be at least those given in **table 1** for minimum high rate.

The minimum air supply rate should be at least the whole building ventilation rate found in step 1.

**For Scotland refer to BRE Digest 398.**

For further information refer to the "Domestic Ventilation Compliance Guide".

### 3.6 Pre Commissioning MRXBOXAB MVHR Units

MRXBOXAB units are designed to ventilate the whole dwelling and must not be used during site construction or the clean-up period. Cement and plaster dust can be abrasive and can affect fan performance and reliability. Please ensure that the filters are checked prior to commissioning to ensure there is no build-up of dust or debris.

While the property is drying out, very high moisture levels are likely to occur. Therefore it is advisable that if the installation and building works are complete the unit is left running. If the building works are not complete please close the air valves or cover up the air valves to prevent condensation forming in the ductwork and the MRXBOXAB unit due to natural migration of warm air.

### 3.7 Dimensions (mm) - Standard Unit Configuration

#### 7 Unit Dimensions (mm) - Standard Unit Configuration

View from top (A)

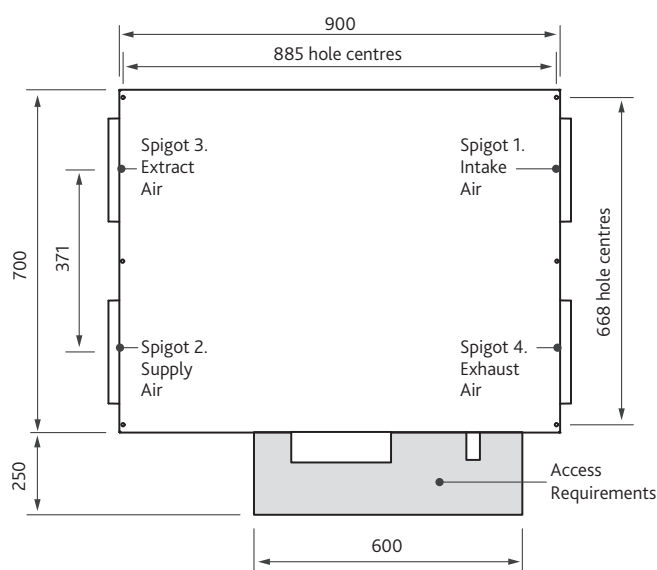

View from control side

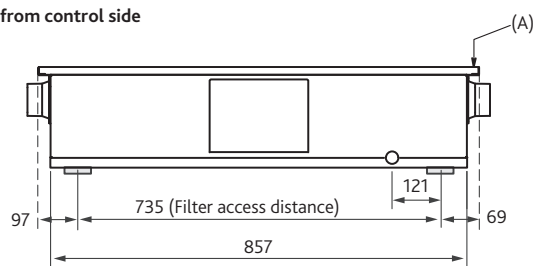

View from underside with cover removed (B)

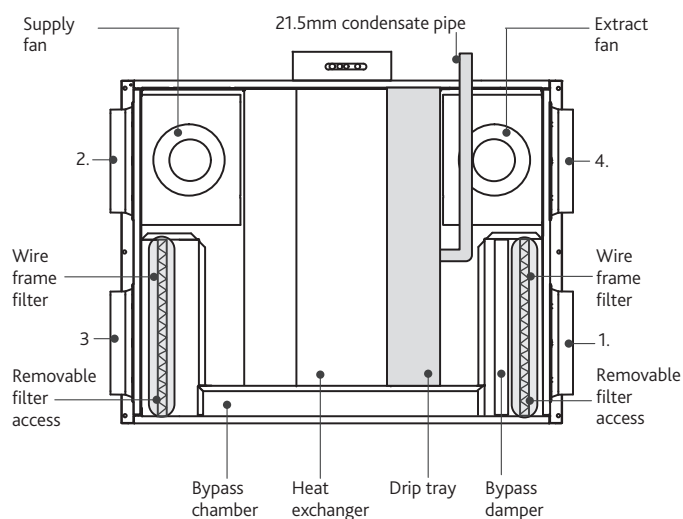

End view

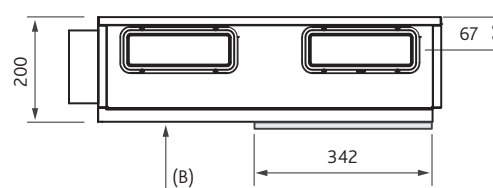

3.8 Typical Ducting Installation - Standard Unit Configuration

8 Typical Ducting Installation - Standard Unit Configuration

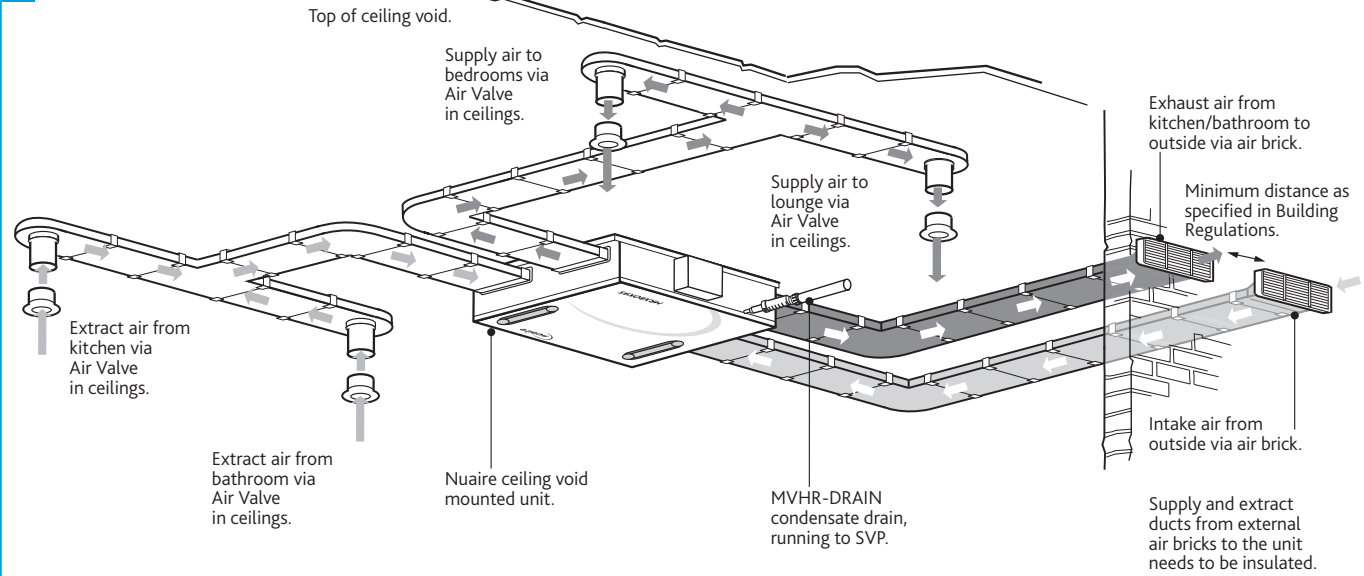

3.9 Dimensions (mm) - Opposite Hand Unit Configuration

9 Dimensions (mm) - Opposite Hand Unit Configuration

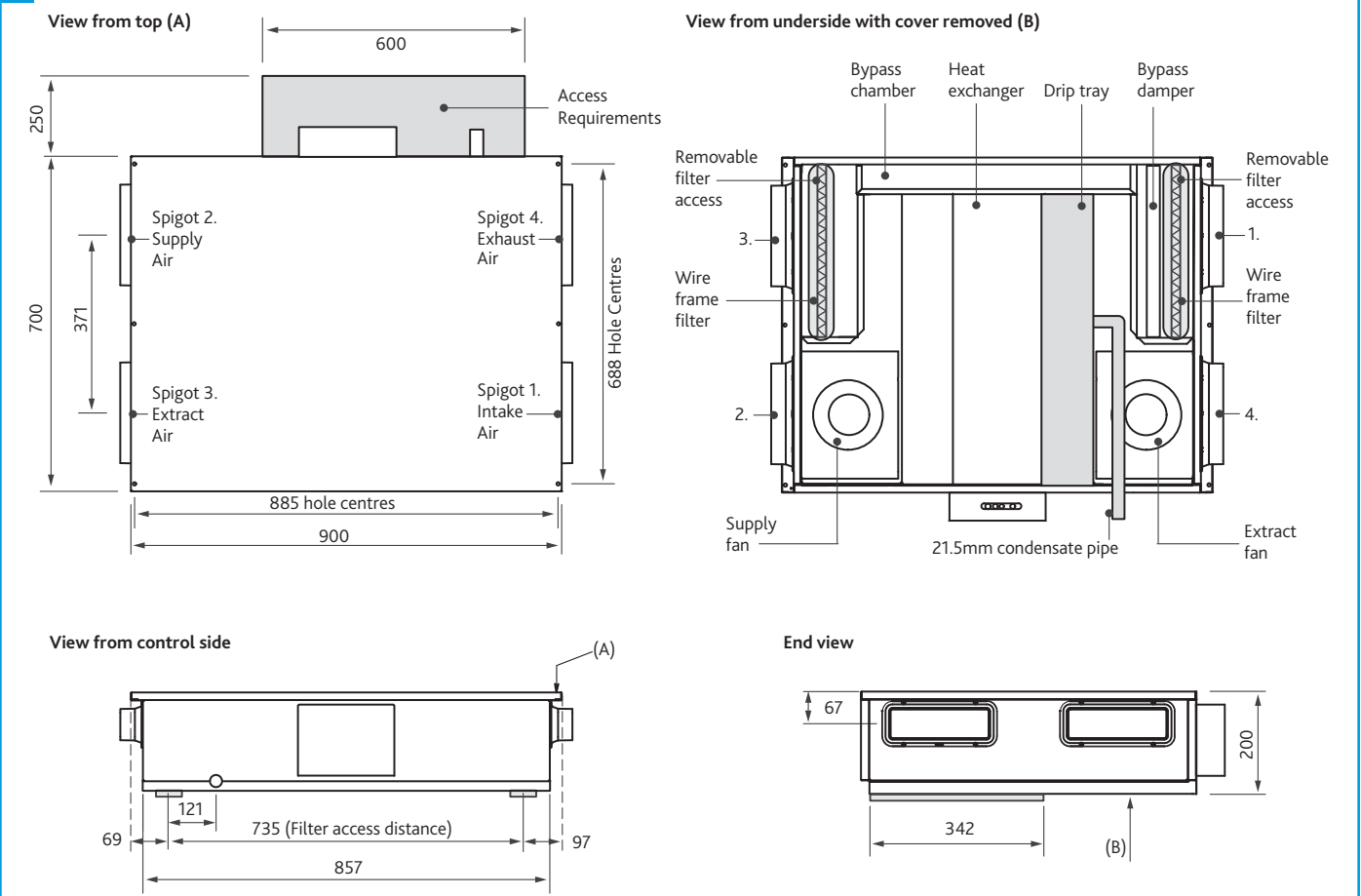

3.10 Typical Ducting Installation - Opposite Hand Unit Configuration

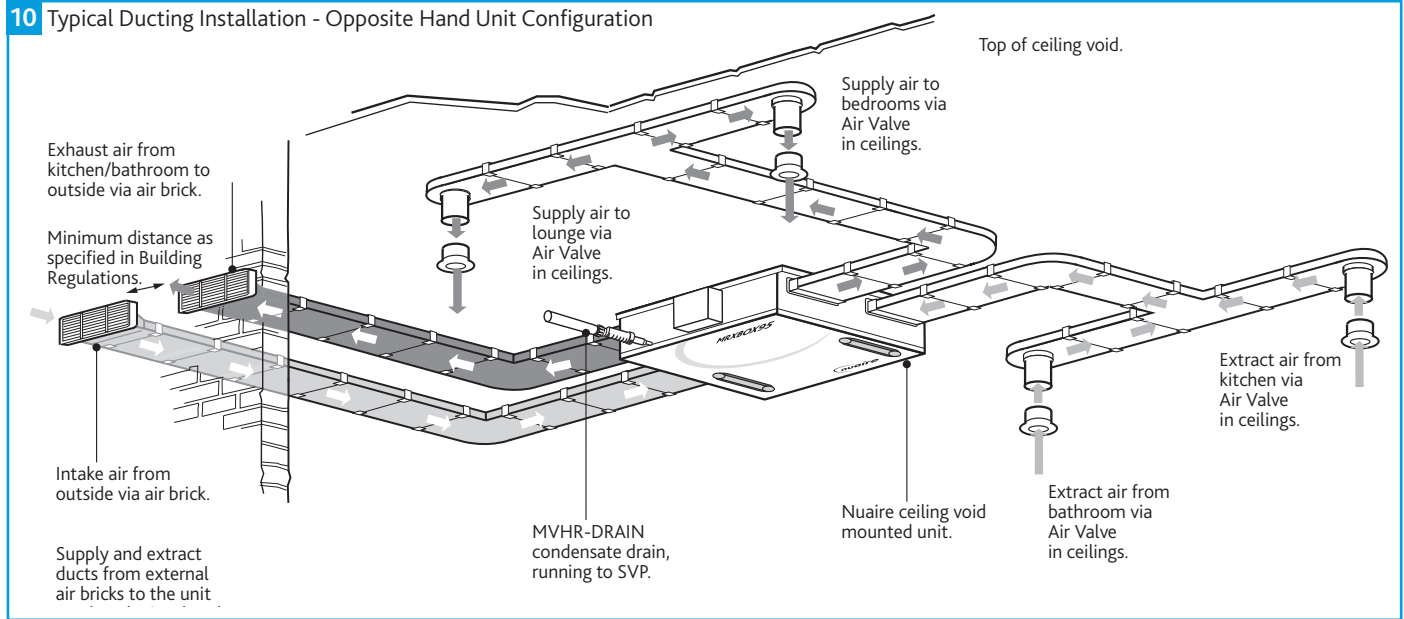

4.0 ELECTRICAL INSTALLATION

For good EMC engineering practice, any sensor cables or switched live cables should not be placed within 50mm of other cables or on the same metal cable tray as other cables.

The electrical connection of the unit must be carried out by a qualified electrician.

The unit is supplied with a flexible cord for connection to the mains supply.

4.1 Electrical Information

Electrical details:

Voltage: 240V 1ph 50Hz

Consumption: 1.3 Amp

This unit must be earthed.

The cable from the mains power supply should be connected to a fixed wiring installation, via a fused isolator, in accordance with current IEE wiring regulations.

Wiring is for reference purposes only as the connections in Figure 11 are factory fitted. The unit is pre-wired with a 2 metre fly lead.

For Ecosmart sensors/controls cut a slit in the grommet and feed the Ecosmart connector through to retain sufficient protection against water ingress. Ensure Ecosmart cabling is secured with P-clips supplied to provide suitable cable retention.

If more than one Ecosmart sensor is required please use MRXBOX-JB and refer to leaflet No. 671700 for installation instructions.

4.3 Wiring Diagrams

4.3.1 Unit Serving Kitchen & Bathroom

Disconnection from the supply mains must be incorporated within the fixed wiring in accordance with the wiring regulations and shall have a minimum contact separation of 3mm.

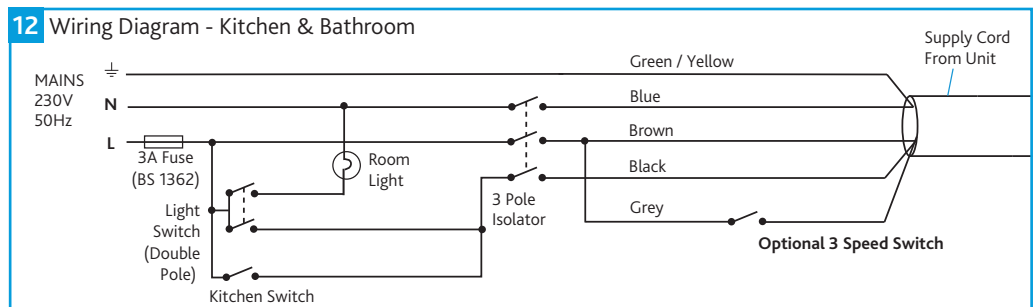

4.2 PCB Details

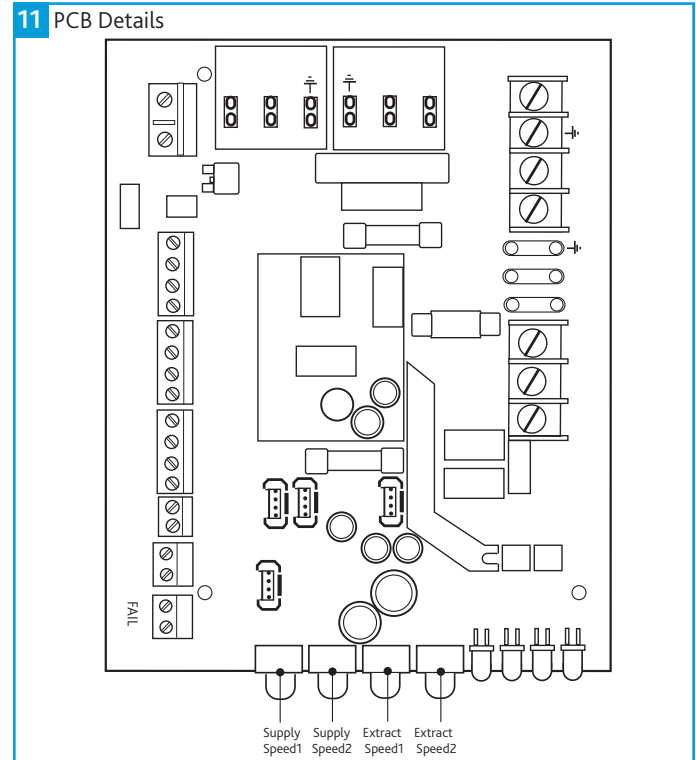

4.3.2 Unit Serving Kitchen & 2 Bathrooms

Disconnection from the supply mains must be incorporated within the fixed wiring in accordance with the wiring regulations and shall have a minimum contact separation of 3mm.

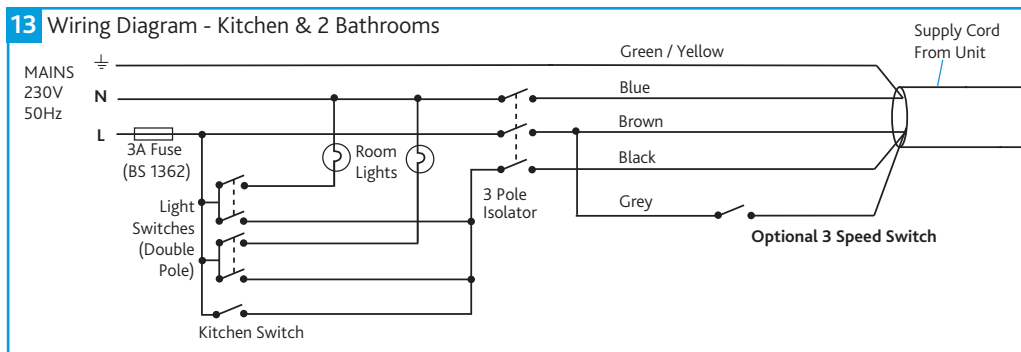

5.0 COMMISSIONING

The filters fitted inside the unit are protected with a plastic film. Prior to commissioning remove the covers (Figure 14), take off the film and replace.

- For the required air flow rates please refer to the design specification for the property, follow Section 3.5, or refer to building regulations ADF 2010.
- The unit is supplied with independent control for both normal and boost airflows (Figure 14).
- Correct commissioning is essential to ensure the ventilation air flowrates are met. It also ensures the unit is not over ventilating and causing excessive power consumption.
- Commissioning should be carried out in accordance with building regulations document "Domestic ventilation compliance guide".

A calibrated moving vane anemometer and hood will be required to carry out commissioning.

- Adjustment valves should be locked in place to prevent further adjustment.
- Once commissioned the home owner / tenant should be informed that the unit should not be adjusted as it will have a detrimental effect on the indoor air quality and could result in condensation and mould growth. The label covering the control has an adhesive panel which should be removed post commissioning to prevent tampering.

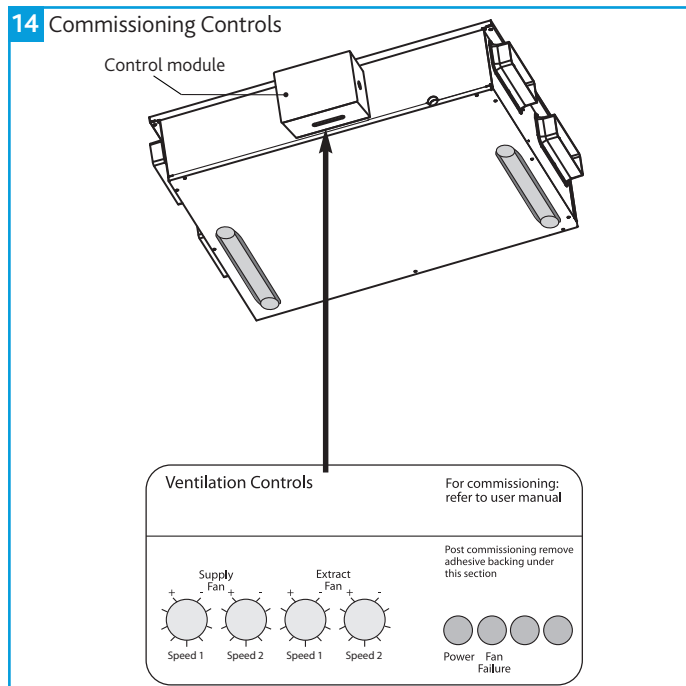

6.0 CONTROLS

6.1 Integral Automatic HX Bypass (AB Units Only)

Intake and extract temperatures are monitored at the point the airflows enter the unit, if the range falls within the set parameters the bypass damper is opened automatically to target an indoor comfort temperature all year round.

The extract temperature is an average from all wet rooms. If this exceeds 25°C the unit may go into bypass depending on outside temperatures.

6.2 Frost Protection

In the event of the intake air temperature at the unit dropping below the predetermined set point (-5°C as standard) the supply fan will reduce to minimum speed, once the temperature rises above the set point the fan will return to its commissioned speed.

This mode will only activate after ten days of continuous run time. If commissioning of the unit is outside of this time frame please notify the after sales department prior to site visit.

6.3 Status Indication

The status of the unit is indicated by a series of LED's on the control box cover. The variants are listed below.

The display on the unit control panel will not indicate when a higher speed setting has been triggered by an external source, such as an ES-PIR2 etc.

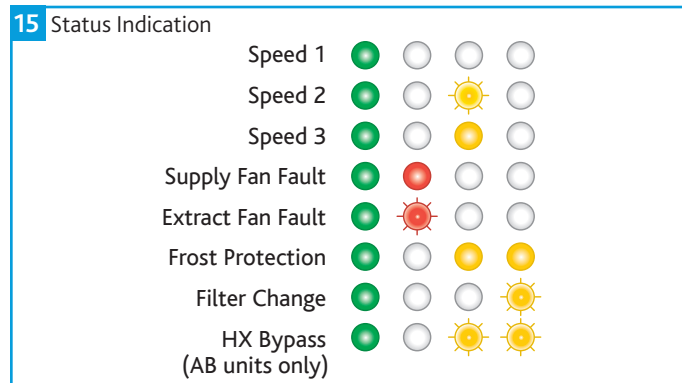

## 7.0 MAINTENANCE

It is important that maintenance checks are recorded and that the schedule is always adhered to, in all cases, the previous report should be referred to.

**Isolation - Before commencing work make sure that the unit, switched live and control are electrically isolated from the mains supply and switched live supply.**

### 7.1 Filter Replacement

Filters are to be inspected every 6 months and replaced every 12 months (or sooner if required). **Failure to do so may impair the performance and energy efficiency of this unit.** A flashing LED (Section 6.2) will indicate that a filter change is required. This indication repeats every 12 months and will turn off automatically after 5 Days.

Remove the filter covers on the front panel of the unit by gripping the two circular tabs either end of the filter covers and pulling away from the unit. The filter can now be extracted by pulling the removal loop on the front edge of the filter. Once the filters have been inspected return or replace them as necessary.

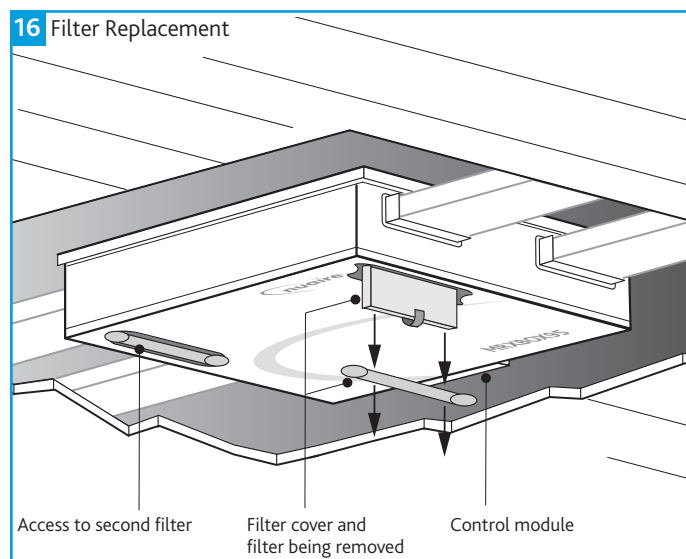

## 8.0 WARRANTY

The 5 year warranty starts from the day of delivery and includes parts and labour for the first year. The remaining period covers replacement parts only.

This warranty is void if the equipment is modified without authorisation, is incorrectly applied, misused, disassembled, or not installed, commissioned and maintained in accordance with the details contained in this manual and general good practice.

The product warranty applies to the UK mainland and in accordance with Clause 14 of our Conditions of Sale. Customers purchasing from outside of the UK should contact Nuaire International Sales office for further details.

**Failure to maintain the unit as recommended will invalidate the warranty.**

## 9.0 END-OF-LIFE AND RECYCLING

Where possible Nuaire use components which can be largely recycled when the product reaches its end-of-life:

- Fans, motors, controls, actuators, cabling and other electrical components can be segregated into WEEE recycling streams.
- Sheet metal parts, aluminium extrusion, heating/cooling coils and other metallic items can be segregated and fully recycled.
- EPP, plastic ducting, nylon corner pieces, plastic heat exchangers, packaging material and other plastic components can be segregated into mixed plastic and widely recycled.
- Cardboard packaging, wood, used filters and other paper components can be largely recycled or fully processed in energy from waste centres.
- Remaining Items can be further segregated and processed in accordance with the zero waste hierarchy. Please call After Sales Support for further information on items not listed above.

**Ensure that Nuaire product is made safe from any electrical / water / refrigerant supplies before dismantling commences. This work should only be undertaken by a qualified person in accordance with local authority regulations and guidelines, taking into account all site based risks.**

## 10.0 AFTER SALES AND REPLACEMENT PARTS

For technical assistance or further product information, including spare parts and replacement components, please contact the After Sales Department.

If ordering spares please quote the serial number of the unit together with the part number, if the part number is not known please give a full description of the part required. The serial number will be found on the identification plate attached to the unit casing.

**The supply cable must be replaced by an electrically competent person.**

**Telephone 02920 858 400**  
**aftersales@nuaire.co.uk**

Technical or commercial considerations may, from time to time, make it necessary to alter the design, performance and dimensions of equipment and the right is reserved to make such changes without prior notice.